



OPTOCORE



Operating Manual for OPTOCORE PTP32E

OPTICAL DIGITAL POINT-TO-POINT SYSTEM

© Copyright 2007 All rights reserved.

OPTOCORE GmbH
Lisbergstr. 7
81249 Munich
Germany

Important Safety Instructions

- Please read this manual carefully.
- Please keep this operating manual in a safe place.
- Heed all warnings.
- Follow all instructions.
- This device may only be used in accordance to the information provided in this operating manual. Ensure that all recommendations, especially the safety recommendations as detailed in this operating manual, are followed before and during the usage of the device.
- Do not use this device near water, for example, in moist or damp rooms.
- Clean only with a dry cloth.
- Do not block or cover any ventilation slits. Install the device in accordance to the operating manual.
- Do not install or place the device near any heat source such as radiators, power-amplifiers, stoves, or any other heat producing equipment.
- Protect the power cord from being walked on, crushed, pinched, or damaged in any other way. Pay special attention to plugs and sockets of the device.
- Never switch on power amplifiers before the complete system is stable and the level meters of the OPTOCORE CONTROL software indicate a normal level.
- Do not place this device on an unstable table, tripod, cart, etc. The device may fall, causing serious damage to the device, and a risk of injury.
- The device can only be removed from the power supply by pulling the plug. This must be freely accessible at all times. The device has to be disconnected during lightning storms or when unused for long periods of time.
- The device must be grounded; any disconnection of the grounding is not permitted.
- The switched-mode power supplies operate with high voltage. Coming into contact with them can lead to considerable electric shocks, which may result in death.
- Only use attachments specified by the manufacturer.
- This device contains no user serviceable parts: only refer to authorized, qualified service personnel for any servicing.
- Your warranty will be voided if you tamper with the internal components.

Purchaser Information

- **Operating Manual**

Please read this manual – if you call for technical support, we'll assume that you have. Study the operating manual carefully in order to familiarize yourself with the device and its operation. It contains numerous information and hints for the proper use of the device.

It cannot be excluded that this operation manual shows typographical mistakes or misprints; it is however regularly revised.

Modifications, which serve the purpose of technical improvement of the device, may be carried out without prior notification.

- **Transport and Shipping**

Always ensure the careful handling of the device. If possible transport or shipping should always occur in special, shock-absorbing transport cases. If these are not available we recommend well-upholstered packaging such as the coated carton in which the device was delivered.

We strongly advise not to use simple flight-cases without rack-in-rack mounting.

- **Environments**

This device can be used in E1, E2, E3, E4, or E5 environments (as listed below) according to the harmonized European standards EN55103-1 and EN55103-2 "Electromagnetic compatibility – Product family standard for audio, video and audio-visual and entertainment lighting control apparatus for professional use"

E1-Residential

E2-Commercial and light industrial

E3-Urban outdoors

E4-Controlled EMC environment e.g. broadcast and TV-studio

E5-Heavy industry

The product is intended for the use in moderate climate.

- **Ventilation**

Do not block or cover any ventilation slits. Install the device in accordance to the operating manual. Leave sufficient ventilation space around the units (at least approx. 200 mm \equiv 7,87" free space behind the rear-panel) and care for free air movement near the ventilation-slits on both sides of the device. Keep the rear of the rack open during operation. Do not set up the device close to equipment producing a lot of heat, for example power-amplifiers. Leave enough space (minimum $\frac{1}{2}$ RU) to any heat emitting device. A PTP32E may be placed on top or beneath other Optocore products, except DD32, without additional space.

- **Water and Moisture etc.**

To prevent fire or shock hazard do not expose device to the effects of direct sunlight, dust, water, or rain during operation or storage.

- **Cleaning**

Only use a dry linen cloth to clean the device. In case of strong soiling, moisten the cloth using a little water and a small amount of household detergent. Never use cleansing agents containing solvents to clean the device.

- **Operating and Storage Temperature**

Operating temperature: 0°C ...50°C \equiv 34°F ...122°F; ensure proper ventilation

Storage temperature: -20°C ...60°C \equiv -4°F ...140°F

- **Power Supply**

The device can only be removed from the power supply by pulling the plug. This must be freely accessible at all times. The switched-mode power supplies operate with high voltage. Coming into contact with them can lead to considerable electric shocks, which may result in death.

Never disconnect the main plug by pulling the cable, always pull the plug itself.

Power-supply cords should be routed in such a way that they are not likely to be walked on, crushed, pinched, or damaged in any other way. Pay special attention to the plugs and the sockets of the device.

Replace a damaged power cable immediately.

The device must be grounded; any disconnection of the grounding is not permitted. Always ensure the correct grounding of the device via the main plug. Never cover the grounding terminal of the plug by means of insulation material!

- **Fuse**

The main fuse cannot prevent an unexpected malfunction of electrical components; it is rather there to protect the user and its environment from damage. Therefore never try to replace the main fuse by any other than the specified D1.0A type (1.0A, slow behavior). Never try to repair or bypass a blown main fuse.

- **Lightning**

For additional protection of this device during lightning storms, or when it is left unattended and unused for a long period of time, unplug the power line. This will prevent damage to the device due to lightning and power line surges. Disconnection from the mains power supply can only be achieved by removing the plug from the mains socket.

- **Eye Safety**

This product is a Laser Class 1 product. It complies with IEC 60825-1, FDA 21 CFR 1040.10, and 1040.11.

- **Interference of external objects and/or liquids with the device**

Never push objects of any kind into the device through openings in the casing. They may come in touch with dangerous voltage points or short out parts that could result in a fire or electric shocks. Never spill liquid of any kind on the device.

- **Cables and Accessories**

Only use attachments specified by the manufacturer.

Only use high quality cable material to connect the device. For the optical data connection exclusively use the specified optical waveguide cables. If not in use, ensure that the optical connectors of both, device and waveguide are closed with the provided lids.

Do not place this device on an unstable table, tripod, cart, etc. The device may fall, which can cause injury and serious damage to the device. Any mounting of the device should follow the manufactures instructions, and should use mounting accessory recommended by the manufacturer.

- **Servicing**

Do not attempt to service this device yourself.

This device contains no user serviceable parts: only refer to authorized, qualified service personnel for any servicing.

The opening of the device is not required for operation as there are no user serviceable components located inside the device. The operation of an opened device is not permitted. It can lead to damage of components due to the absence of required ventilation. The device may not be serviced, altered or modified without authorization of Optocore or an Optocore authorized distributor / dealer. Repair and maintenance work may only be carried out by qualified service personnel. The warranty will be voided if unauthorized manipulation occurred.

CE-Conformity

This document confirms that the product PTP32E bearing the CE (Communauté Européenne) label meets all requirements in the EMC directive 2004/108/EG laid down by the Member States Council for adjustment of legal requirements. Furthermore the product complies with the rules and regulations of the low-voltage directive 2006/95/EG. This product bearing the CE label complies with the following standards, ratified by CENELEC (Comité Européen de Normalisation Electrotechnique):

Electromagnetic compatibility – Product family standard for audio, video, audio-visual and entertainment lighting control apparatus for professional use

**EN 55103-1, Emission
EN 55103-2, Immunity**

The authorised declaration and compatibility certification lies with the manufacturer and can be viewed on request. Responsible as manufacturer is:

**OPTOCORE GmbH, Lisbergstr.7, 81249 Munich, Germany
represented by Marc Brunke, Managing Director**

N.B. The awarding of the CE label confirms the compliance with legal directives issued for the manufacture and marketing of electronic and electrical devices. As such the CE label is not a "seal of quality" but rather proof that the device bearing the CE label is conform with the electromagnetic compatibility standards laid down in the above named testing regulations.

Munich, 01.07.2007



Marc Brunke

Eye Safety

This product is a Laser Class 1 product. It complies with IEC 60825-1 and FDA 21 CFR 1040.10 and 1040.11.

PTP32E OPTICAL DIGITAL POINT-to-POINT SYSTEM

Table of Contents

Important Safety Instructions.....	2
Purchaser Information.....	3
CE-Conformity.....	5
Eye Safety.....	5
Device Description	6
Front Panel.....	6
Rear Panel	6
Device Details	6
Fiber Optic Connection	6
Principal Ports for AES/EBU	6
RS485 Auxiliary Ports	6
Word Clock	6
Video Ports	6
Power Supply.....	6
Transmission Delay	6
Control	6
Connecters and Cables.....	6
Optical Connection.....	6
D-Sub-Type-Connection	6
USB-Connection	6
BNC-Connection.....	6
Mains-Connection	6
Starting Up	6
Factory Setting.....	6
Software Installation.....	6
Optocore Point-to-Point Setup	6
Hardware Connection	6
Point-to-Point examples.....	6
Connection Tables	6
Connections to X6-Series	6
Adapters to Third Party AES/EBU Devices.....	6
Technical Specifications.....	6
Dimensions and Weight	6
Warranty.....	6
Shipping Contents.....	6
Company Information.....	6

Device Description

Congratulations on your purchase of a PTP32E Optical Digital Point-to-Point System. The PTP32E will quickly convince you with its advantages and will facilitate your day-to-day work.

The PTP32E is the point-to-point version of its “network brother” DD32E. Using a pair of PTP32E devices is probably the easiest and cost effective way to connect STAGE with FOH. In combination with one PTP32E, all the other Optocore devices such as DD32(E), LX4AP, the interface card YG2 for Yamaha devices, etc. can operate on the other side of the point-to-point fiber optic connection. The PTP32E enables the gain control of Yamaha and Optocore microphone preamps on stage from a Yamaha digital console at FOH. This offers an incredible broad flexibility. The PTP32E can be used in all sorts of temporary and permanent applications, especially when long distance connections, high-quality audio transmission or high security is required.

Depending on the fiber optic transceivers distances from 700 m up to 70 km can be covered.

No losses due to resistance, capacitance or inductance can occur. Nor disturbances inflicted by cables such as power lines or other devices will influence the audio signals. Galvanic isolation between the devices is given, thus ground loops do not exist. In addition, latency caused by the digital devices and transmission is extremely low.

Redundant fiber connections can be established with the two optical LINK-interfaces. The dual power supply unit, with automatic switchover, permits a redundant power supply and safeguards against malfunctions of the unit if one power supply fails to run.

The PTP32E offers 4 principal ports for connection and transport of a total of 32 AES/EBU digital audio channels i.e. 64 mono channels with sample rates up to 192 kHz. These channels are user defined as input or output in groups of four (32 - 0, 28 - 4, 24 - 8, ... , 4 - 28, 0 - 32). The PTP32E also includes bi-directional composite video and word clock interfaces. Four RS485 ports allow the transport of a wide range of standards such as RS422, DMX, MIDI, CAN. In addition to the audio signals the video and data signals are transmitted by the fiber connection.

The dual optical interfaces with data transfer rates of 1Gbps are equipped with SC-connectors, commonly used and absolutely reliable in permanent installations. For rough applications such as touring and live productions the 1 RU OptoCon panel, with rugged and secure fiber optic connectors can be added to the rack.

Using two PTP32Es can easily replace an analog multi-conductor cable, weighing only a fraction of a conventional copper cored one. It is can be the first step when changing from analog to digital equipment.

Due to SMD production the PTP32E fulfills the demand of highest digital standards occupying only one rack unit (RU) of a 19" rack. The FPGA (field programmable gate array) based concept of the internal logic circuitry permits updating of the hardware via the units remote ports, ensuring a continual state-of-the-art device.

Two PTP32E can be purchased with a factory setting, ready configured for plug and play. OPTOCORE CONTROL software is used to change the configuration or define own settings. It provides easy access to all configuration and control tools, including routing, naming, gain setting, and phantom power activation for attached devices such as LX4AP and X6, storage and recall of configurations on the computer, off- and online mode, real-time level display of the individual channels in online mode.

Front Panel

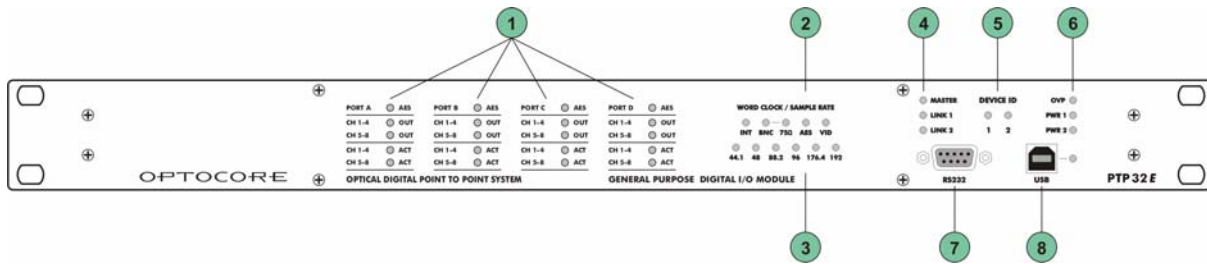

- 1**

AES status LED: Indicates that the entire port (exit on the rear panel) is ready for data transmission of
LED ON: AES/EBU digital audio
LED OFF: Data

Out LED: Configuration of channels 1-4 or 5-8:
LED ON: Outputs
LED OFF: Inputs

ACT LED Signal status of channels 1-4 or 5-8:
LED ON: At least one signal is present
LED OFF: No signal is present
- 2**

Word Clock LED: Indicates the selected word clock source:
INT: Internal word clock
BNC: External via BNC Input
BNC 75 Ω: External via terminated BNC Input (75 Ω)
AES: External via AES
VID: External via video
- 3**

Sample Rate LED: Indicates the selected sample rate
44,1 / 48 / 88,2 / 96 / 176,4 / 192 kHz
- 4**

Master LED: Indicates the master unit
Link 1 LED: Communication is established via LINK 1 (rear panel)
Link 2 LED: Communication is established via LINK 2 (rear panel)
- 5**

Device ID Display: Indicates the identification number of the device
- 6**

OVP LED: Indicates over-voltage protection (> 300 V_{AC})
PWR 1 LED: Power supply 1 is working correctly
PWR 2 LED: Power supply 2 is working correctly
- 7**

RS232 plug: D-Sub-9 RS232 connection for remote control and update via PC
- 8**

USB plug and LED: USB connection for remote control via PC
LED ON indicates USB is connected;
LED blinking indicates data traffic

Rear Panel

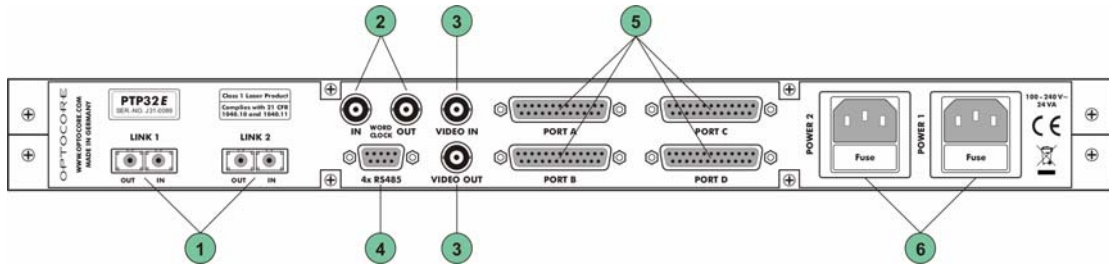

- 1**

LINK 1: Full-duplex, full bandwidth SC-type optical interface for data transmission
LINK 2: Full-duplex, full bandwidth SC-type optical interface for data transmission
- 2**

Word Clock IN: BNC Word clock input allows synchronization of Optocore devices to an external word clock source
Word Clock OUT: BNC Word clock output for synchronization of external devices
- 3**

Video IN: BNC Video input for composite video
Video OUT: BNC Video output for composite video
- 4**

4 x RS485 plug: D-Sub-9 RS485 AUXILIARY PORT for control data transmission
- 5**

PORT A ... D: 4 x D-Sub-25 PRINCIPAL PORTS with 8 channel RS422 for AES/EBU or data transmission
- 6**

POWER 1: Mains input for power supply 1 (100 ... 240 V)
POWER 2: Mains input for power supply 2 (100 ... 240 V)

Device Details

Fiber Optic Connection

The OPTOCORE ® OPTICAL DIGITAL POINT-TO-POINT SYSTEM uses a digital Time Division Multiplex technology (TDM) with a fiber channel based 8B10B-NRZI-coding. Static time slots guarantee the synchronous transmission of all channels at any time with no demand for dynamic bandwidth. All signals attached to the audio, video, word clock and auxiliary ports of the device are transmitted simultaneously on one fiber. The second fiber of one LINK-Interface is used to receive data. The second LINK-Interface has the same features as the first; therefore one of the LINK-Interfaces can always be used for redundancy.

Principal Ports for AES/EBU

According to the AES/EBU standard each physical channel contains two audio channels, i.e. with the 32 digital channels of the four principle ports 64 audio channels are available. The ports feature the unique possibility to define them freely as AES/EBU inputs or AES/EBU outputs in groups of four.

Defining the 32 digital channels as inputs or outputs in groups of four is done with OPTOCORE CONTROL software.

RS485 Auxiliary Ports

The auxiliary ports provide four RS485 interfaces to establish a maximum of four half-duplex or two full-duplex connections between the devices. A wide range of bi-directional and unidirectional standards can be connected, such as RS485, CAN-Bus (bi-directional), or RS422, DMX, MIDI (unidirectional). The interfaces will sense automatically whether they send or receive control data. For setting the destination of each interface OPTOCORE CONTROL software is used.

Word Clock

The word clock input can be used to connect an external word clock source. An alternative clock sources is the internal word clock. The synchronous data transmission with no buffers demands an absolute stable clock throughout the 1 Gbps network. Based on this clock the word clock available at the outputs is of superior quality with extremely low jitter. The word clock outputs can be used for the synchronization of external devices with digital I/Os such as preamps, controllers and consoles. Care has to be taken, that there is just one word clock master and all connected devices with digital I/Os work with the same sample rate.

Video Ports

A video in- and output is incorporated for the transmission of composite video signals.

Power Supply

The device is equipped with two power inputs and power supply units. If one power supply fails, due to malfunction of the feeding power line or the power supply unit itself, the device will automatically switch over to the other power supply unit. In order to make the power supply redundant, both power inputs must be connected to the mains supply, if possible to different phases, power supply systems, or even better, one of them to an uninterrupted power supply (UPS).

The power supply units operate with mains voltage of 100 ... 240 V and frequency of 50 ... 60 Hz. Thus the device can be used throughout the world without any adjustments or transformers.

The power supply units are 400 V_{AC} tolerant and protected against high current. The OVP (Over Voltage Protection) LED on the front will indicate over voltage at > 300 V, simultaneously suppressing the normal function of the device. When the OVP LED is lit, immediately disconnect the device from the power line to prevent any damage to the device. Both power inputs have a fuse, replaceable without opening the device.

Never bypass the fuse and only use the specified type.

Be aware that the switched-mode power supplies operate with high voltages! Coming into contact with them can lead to considerable electric shocks that may result in death! To prevent electric shocks do not remove any covers!

Transmission Delay

The Optocore system delay including the matrix is fixed to 41,6 µs for all channels. The transport delay per Optocore unit (< 200 ns) is insignificant. The transmission delay is constant from any point to any point. Overall delay depends on converters and fiber cable length, with 'normal' cable lengths of < 700 m it can also be considered as marginal.

Control

All system and device parameters are set with the OPTOCORE CONTROL software on a PC, connected to the device via RS232 or USB port. It is sufficient to connect one unit to get control over the whole system. Third party protocols for device controlling, if previously adapted by Optocore, can be used. An example is the "Yamaha Emulation Mode" (YEM) to control the Optocore mic preamps from a Yamaha-console.

Connecters and Cables

Optical Connection

The dual optical LINK-interfaces are equipped with duplex SC connectors. Standard SC cables with two fibers can be used. Worst case reach is 700 m with multimode transceivers and a 50 μm fiber, whilst with mono-mode transceivers and a 9 μm fiber, up to 70 km are possible. For rugged applications e.g. touring and other temporary installations, HMA Expanded Beam Connectors mounted on 1 RU panel are available, along with matching, inter-connection cables transported on cable drums. (Please refer to [Product_Brochure_2007.pdf](#) available at www.optocore.com).

D-Sub-Type-Connection

The following types of cables and connector housings are recommended:

Principal and Auxiliary Ports

According to the RS422/RS485 hardware standard, each channel requires a twisted pair. A common braided shield should enclose the pairs.

Standard computer data cables are absolutely sufficient for good quality AES data transmissions over the short distances typically necessary in applications.

The following cable types have been tested:

- Multi-core data cable with common braided shield, Cu-stranded wire 18 X 0.10 mm², nominal gauge 0.14mm², PVC-isolation, outer-diameter 1.05mm, Resistance max. 138m Ω /m, Capacity max. 120pF/m.
- 8-wire, 4-pairs, common braided shield, outer-diameter 6.6mm
- 16-wire, 8-pairs, common braided shield, outer-diameter 8.8mm

RS232-Connection

Shielded, standard 1-modem cable is sufficient for the RS232 port.

Connector Hood Quality

Applied locking screws for the D-Sub-types must be acc. to 4-40 UNC. Care should be taken in selecting the right types of connector hoods in order to fulfill the requirements of EMI-radiation directives. Full metal connector hoods should be used, approved acc. to VDE 0871, FCC 20780 and EMC directive 2004/108/EG, providing an reduction > 40 dB on 30 MHz up to 1 GHz. The shielding harness of the cable should have complete contact to the connector hood.

USB-Connection

For the USB-port use a standard PC / device cable.

BNC-Connection

Word Clock connection: 75 Ω -BNC

Mains-Connection

Standard power cords with IEC C13 socket can be used.

Starting Up

Factory Setting

If two PTP32E devices are purchased with a factory setting the system is ready for use. Same counts for devices configured beforehand. If the control facilities are not needed and changes of configuration are not necessary, no computer has to be attached to the PTP32E.

The factory setting is as follows:

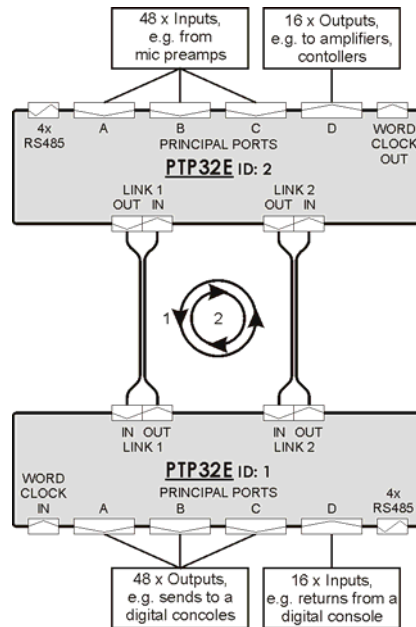

Fig. 1: Factory setting of a redundant Point-to-Point System

FOH Unit with ID 1:

Master	This device determines the clock source and sample rate. If an external clock sources is used, it has to be connected to this devices.
Outputs	Port A, B, C are defined as outputs. Each port sends eight AES/EBU, i.e. 16 mono channels; the total number of outputs is 48 channels.
Inputs	Port D is defined as input. The port receives eight AES/EBU, i.e. 16 mono channels.

Stage Unit with ID 2:

Slave	This device gets the word clock and sample rate from the master. To synchronize other external devices with the PTP32E system, the word clock out can be used.
Outputs	Port D is defined as output. The port sends eight AES/EBU, i.e. 16 mono channels.
Inputs	Port A, B, C are defined as input. Each port receives eight AES/EBU, i.e. 16 mono channels; the total number of inputs is 48 channels.

Factory configured devices can be changed at any time using a PC and the OPTOCORE CONTROL software. PC and software will offer utmost flexibility for last-minute changes and overall control.

In case factory settings are changed using the OPTOCORE CONTROL software please pay attention to the correct assignment of IDs and channels via “Local Settings”.

For this reason we do strongly advice to get familiar with OPTOCORE CONTROL.

Software Installation

Installation requirement for the software is a functioning computer system with Microsoft® Windows 95/98/2000/NT/XP/Vista® operating system. The computer should be equipped with an USB interface for configuration and remote controlling, and a RS232 interface (or an appropriate USB / RS232 adapter) for firmware upgrade. COM 1...4 can be used with a transfer rate of 57 600 Baud. Monitor resolutions of 800 x 600 or 1024 x 768 with 16 Bit color rendering are recommended to view the program. The installation requires approx. 2.5MB of hard-disk space and is carried out in the usual Windows-program manner.

Please note that the serial interfaces on computers are not usually capable of “Hot Plugging”. Switch off the computer to avoid damage before establishing the serial connection between the Optocore device and the computer.

The set-up software *OCSETUPXXX.EXE* is available on CD or can be downloaded from www.optocore.com. OPTOCORE CONTROL for configuration and remote controlling, and OPTOCORE UPGRADE for firmware upgrading are installed on a PC or Laptop by double-clicking on the *OCSETUPXXX.EXE*. The set-up executable program is self-extracting and provides the OPTOCORE CONTROL SETUP WIZARD. It will establish the necessary directories, a desktop icon for the OPTOCORE CONTROL and firmware upgrade software.

The uninstall procedure of OPTOCORE CONTROL can be carried out with the *ADD OR REMOVE PROGRAMS* tool of Windows, which is usually found under *START / CONTROL PANEL*.

For details about features and handling of OPTOCORE CONTROL please refer to the *HELP* menu of the software. We strongly recommend getting familiar with the OPTOCORE CONTROL software.

Optocore Point-to-Point Setup

Before connecting a PTP32E to any other device and before establishing the optical LINK connection make sure that the devices have a basic set-up in order to be able to operate correctly. For operation safety reasons, some settings (e.g. “ID”) may only be made when locally connected to a device.

All devices in the network must operate with the same firmware version. The firmware version can be revised under *SET / LOCAL SETTINGS*. The update of the firmware is done with the OPTOCORE UPGRADE software under *START / PROGRAM / OPTOCORE / UPGRADE*. Please refer to the *HELP* Menu for further information. For firmware updates the PC has to be connected via the RS232 Port on the front of the device.

The best approach to check the settings is to connect locally to every single device with a PC using either RS232 or USB connection, run the OPTOCORE CONTROL software and enter menu *SET / LOCAL SETTINGS*. This dialog enables the definition of the ID, ports, etc.

- **General -> ID:** The devices in the Point-to-Point System can be assigned to ID 1 or ID 2. Both devices must have a different ID. The device with the lowest ID will determine the clock of the network. It is advisable to assign the ID 1 to the device connected to the most important console, e.g. the FOH console.
- **General -> PTP32E mode:** If an Optocore device such as LX4AP, YG2, DD32(E), DD4ME is part of the Point-to-Point System, the check box *PTP32E MODE* must be marked.
- **General -> Local Settings:** The principle ports can be configured under *PORT SETUP* while locally connected to the device. The settings can be changed in *OFFLINE* Mode with *NETWORK LOCAL SETTINGS* via the network. *RS485 SETUP* and *VIDEO SETUP* are adjustable *ONLINE* and *OFFLINE*.
- **RS485 Ports:** The *RS485 SETUP* is used to define which signal is given out at the specific port of the device. It is not necessary to define any inputs. If the BI-C cable is connected (as shown in chapter “BI-C Cable”), the RS485 ports 3 and 4 will send or receive data.

To illustrate the setting of the ports in OPTOCORE CONTROL the Yamaha remote data transfer from a Yamaha console to AD8HR mic-preamps will be used as an example. A PTP32(E) at FOH with ID 1 will transmit data to the console at Port 3 and receive data at Port 4. The PTP32(E) with ID 2 at the position of the preamps will transmit data to one of the AD8HRs at Port 3 and receive data at Port 4 as well. Accordingly the data received at ID 2 / Port 4 has to be transmitted by ID 1 / Port 3 to the remote port of the console. This is the return path from the preamps to the console. In order to enable this connection the *RS485 SETUP* of the FOH device with ID 1 is:

Local settings for	Device (where the data is received)	Port (where the data is received)
ID1 / Port 3	ID 2	Port 4

None of the other RS485 Ports have to be adjusted and can be disabled. The definition of the ports as *DISABLED* only declares that they are not used as outputs. Data received at the disabled ports will be transported to any destination by the fiber optic connection.

To establish the command path from the console to the preamps the *RS485 SETUP* of ID 2 is:

Local settings for	Device (where the data is received)	Port (where the data is received)
ID2 / Port 3	ID 1	Port 4

Click on *WRITE* first, confirm with *OK*, and then click *CLOSE* to exit the dialog.

You may now connect the optical LINK cables between all Optocore devices.

Check your setup by connecting to any device using either RS232 or USB connection, running the OPTOCORE CONTROL software and starting *ONLINE MODE* in the *SET* menu. The entire network at its current state is now displayed in the control software. Check the *LOG WINDOW* for any error messages. All Optocore devices memorize the current setup, even if they are switched off or disconnected from the power supply.

Never switch on power amplifiers before the complete system is stable and the OPTOCORE CONTROL level meters indicates a normal level.

Hardware Connection

To get the Point-to-Point PTP32E system going, connect the LINK-interfaces of the two devices with an appropriate fiber optic cable as described in the chapter "Optical Connection". One duplex SC cable is sufficient; the connection will be redundant by linking up the second LINK-interfaces as well. The principle ports can be connected to any device with AES/EBU interfaces. For the D-Sub-25 pin assignment relate to the "Connection Tables". These also show the assignment of RS485, RS232 and USB.

The following examples demonstrate a principal wiring of a PTP32E system:

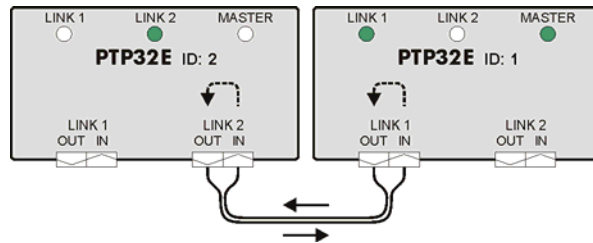

Fig. 2: Two PTP32E in a non-redundant Point-to-Point system

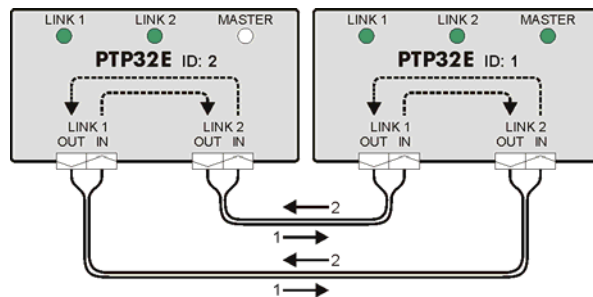

Fig. 3: Two PTP32E in a redundant Point-to-Point system

Point-to-Point Examples

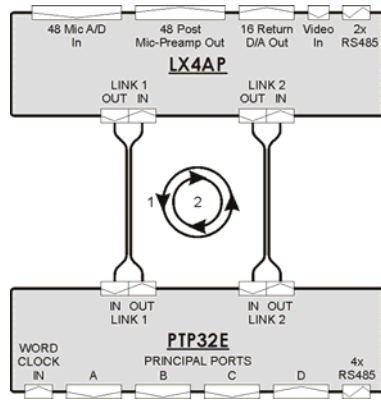

Fig. 4: Redundant system with one PTP32E and one LX4AP in a simple 48 send / 16 return configuration

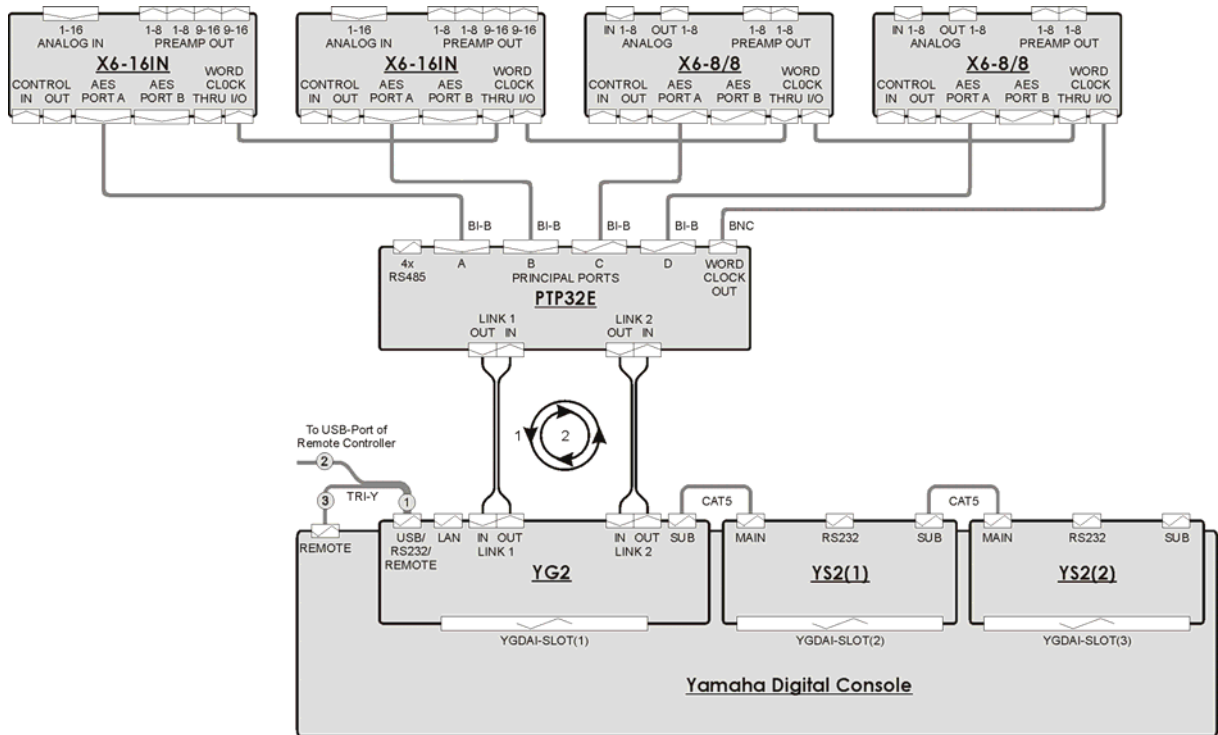
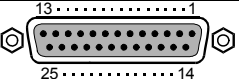
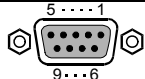

Fig. 5: Wiring of a system with PTP32(E), X6-converter units and a Yamaha console with YG2/YS2 cards. In order to control the X6-converter at the console the Yamaha Emulation Mode (YEM) must be activated in OPTOCORE CONTROL. Yamaha preamps connected to the PTP32(E) will use the fiber optical connection only for the bi-directional transfer of RS485 data and no special mode is activated.

Connection Tables

PTP32E Ports

Pin-out		Principal Ports A - D										
	AES Channel	AES/EBU In or Output				AES/EBU In or Output				Special use		GND
	Audio Channel	1	2	3	4	5	6	7	8	9	10	
	Pin	+	1	2	3	4	5	6	7	8	11	24
	-	14	15	16	17	18	19	20	21	9	22	
D-Sub-25- female												Locking system acc. to 4-40 UNC

Pin-out		Auxiliary Ports 4 x RS485						
	Channel	RS485				GND	Please assure correct polarity “+” and “-” at both (!) sides / devices when connecting external equipment to the RS485 ports.	
	Pin	+	1	2	3			4
		-	6	7	8	9		
D-Sub-9- female								Locking system acc. to 4-40 UNC

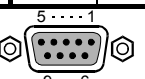
Pin-out		RS232-Port						
	Channel	RS232		Internally Bridged	Power		Use 1-modem cable, male – female, to connect to PC	
	Pin	RXD	TXD		+5VS	GND		
		3	2	1, 4, 6	7, 8	9		5
D-Sub-9- female								Locking system acc. to 4-40 UNC

Pin-out		USB-Port				
	Channel	USB			GND	USB device-connector
	Pin	VBUS	D -	D +		
	1	2	3	4		

Connections to X6-Series

In order to connect a principal port of a PTP32E to an AES port of an X6-series converter device, as shown in Fig. 5 in the chapter "Point-to-Point Examples", a BI-B D-Sub-25 cable is used. All adjustments concerning the definition as inputs or outputs is done by OPTOCORE CONTROL under *SET / LOCAL SETTINGS / PORT SETUP*:

PTP32(E) Principal Port
 X1...X8: 16 channels
 X9, X10: Control channels
 D-Sub-25-male
 Fastening system: 4-40 UNC

X6-series AES Port
 X1...X8: 16 channels
 X9, X10: Control channels
 D-Sub-25-male
 Fastening system: 4-40 UNC

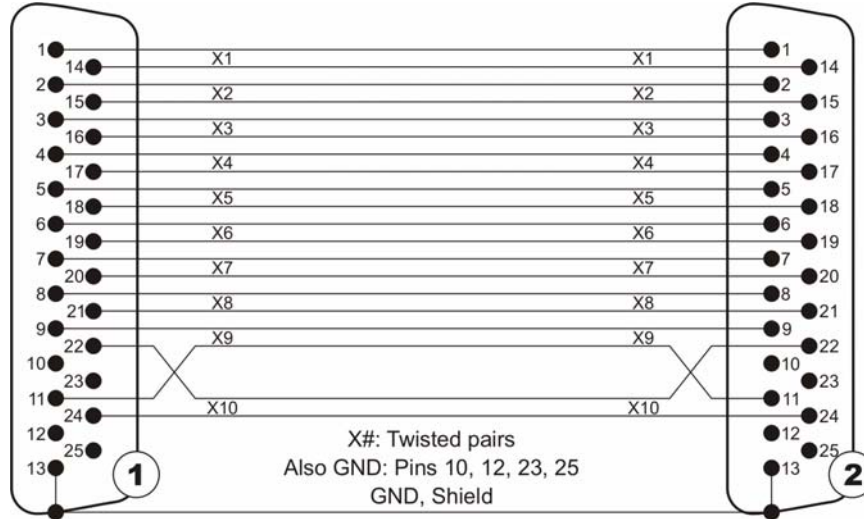

Adapters to Third Party AES/EBU Devices

When the PTP32(E) is combined with third party devices compatible to the Yamaha standard pin-out the following adapters are used to connect the D-Sub-25 ports:

The pin-out to connect a PTP32(E) principal port with 8 output channels and 8 input channels to 8 inputs and 8 outputs of a Yamaha MY8-AE- or MY16-AE-card is:

PTP32(E) Principal Port
 X1...X4: 8 outputs
 X5...X8: 8 inputs
 D-Sub-25-male
 Fastening system: 4-40 UNC

MY8(16)-AE
 X1...X4: 8 inputs
 X5...X8: 8 Outputs
 D-Sub-25-male
 Fastening system: Metric M2.6

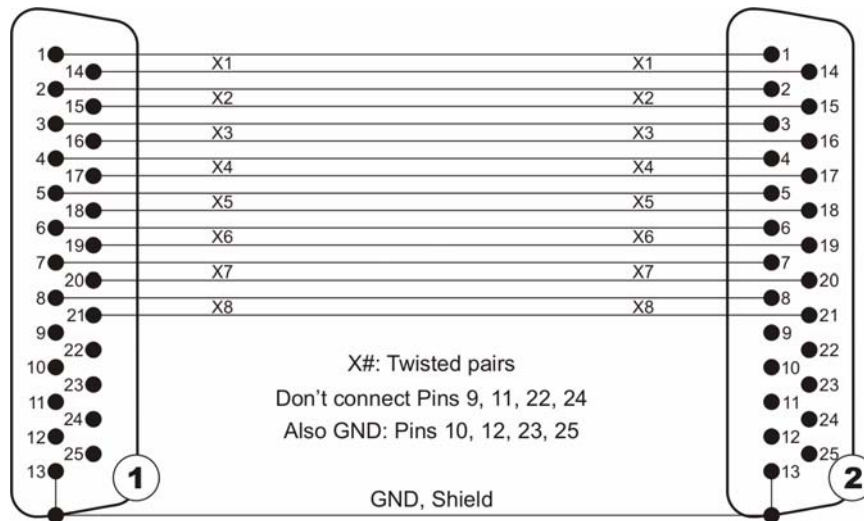

In order to link the 8 PTP32(E) outputs to the 8 MY8(16)-AE inputs and the 8 PTP32(E) inputs to the 8 MY8(16)-AE outputs the I/O configuration of the Optocore port has to be *8/8 REVERSE*. This is set in OPTOCORE CONTROL under *SET / LOCAL SETTINGS / PORT SETUP*.

TRI-A Split Cable

The D-Sub-25 TRI-A is used to connect a PTP32(E) principal port with 16 audio outputs to two 8 channel input ports of a Yamaha MY8-AE- or MY16-AE-card in a console, a DA842, etc.

PTP32(E) Principal Port
(1) X1...X8: 16 outputs
 D-Sub-25-male
 Fastening system: 4-40 UNC

MY8(16)-AE
(2) X1...X4: 8 inputs
(3) X5...X8: 8 inputs
 D-Sub-25-male
 Fastening system: Metric M2.6

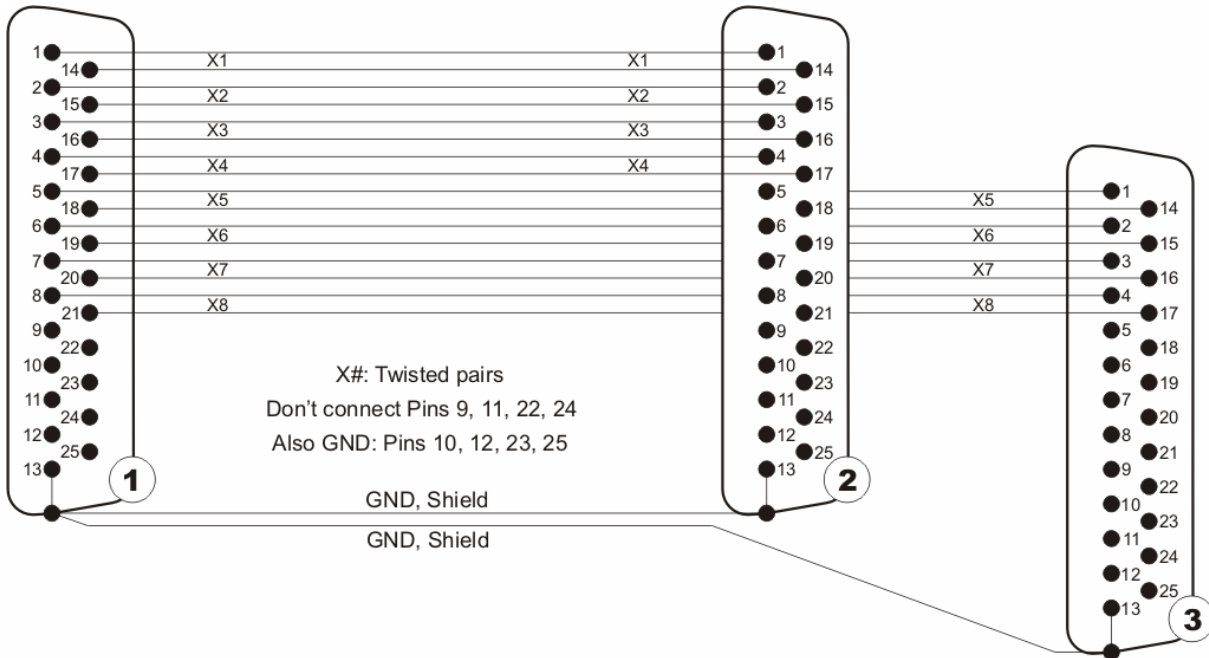

TRI-B Split Cable

The D-Sub-25 TRI-B is used to connect a PTP32(E) principal port with 16 audio inputs to two 8-channel output ports of a Yamaha A/D converter such as the AD8HR, the MY8-AE- or MY16-AE-card in a console, etc.

PTP32(E) Principal Port
(1) X1...X8: 16 inputs
 D-Sub-25-male
 Fastening system: 4-40 UNC

MY8(16)-AE
(2) X1...X4: 8 outputs
(3) X5...X8: 8 outputs
 D-Sub-25-male
 Fastening system: Metric M2.6

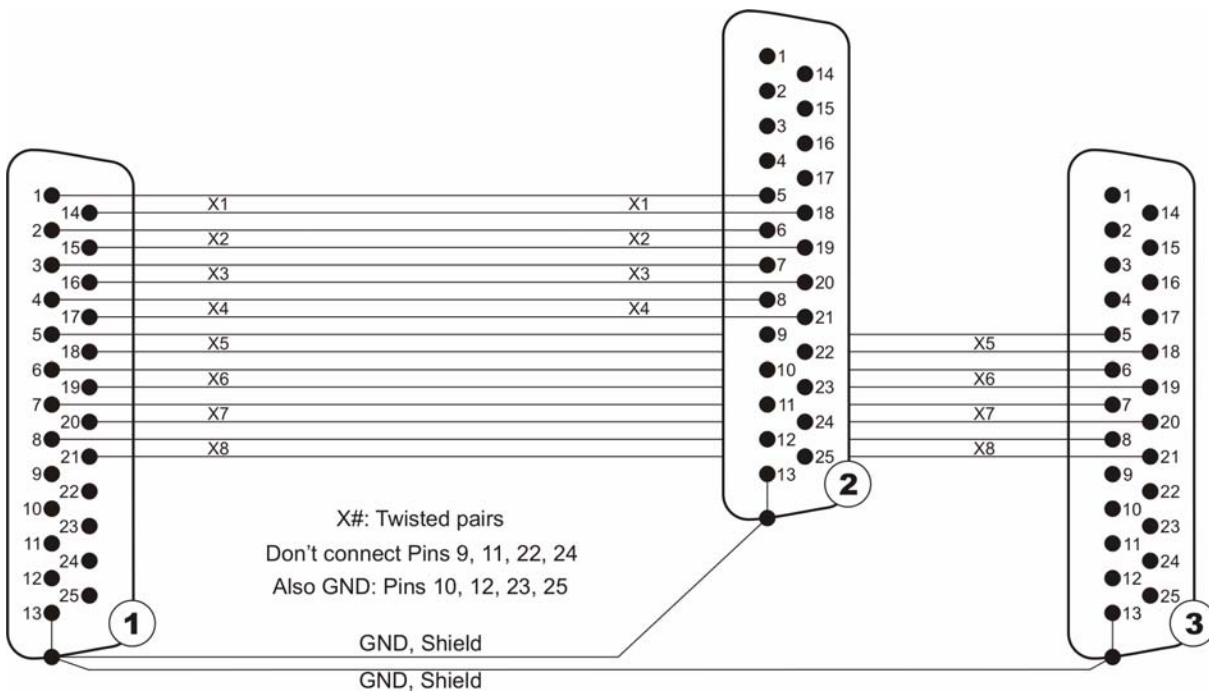

BI-C Cable

The D-Sub-9 BI-C enables the bi-directional transmission of control data. The RS485 Ports 3 and 4 of the PTP32(E) are used.

PTP32(E) Auxiliary Port 4 x
RS485
X3...X4: I/Os
D-Sub-9-male
Fastening system 4-40 UNC

COM RS422
X3: R x D
X4: T x D
D-Sub-9-female
Fastening system 4-40 UNC

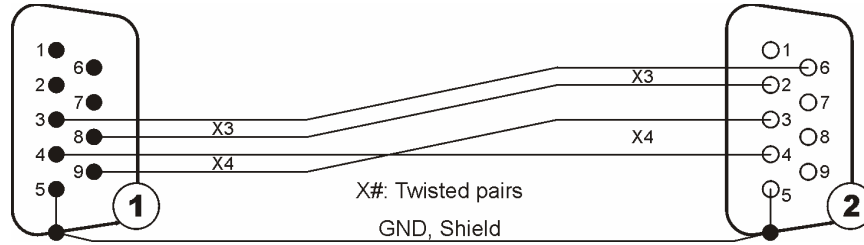

Technical Specifications

Principal Ports		
	Convention EIA / TIA-422	
Data channels	Digital data, AES/EBU	32
	AES/EBU audio channels	64
Data rate	Depending on used sample rate	Up to 30 Mbps
Impedance	Termination	330 Ω
	Source	≤ 10 Ω
Drive level	Output	≥ 2 V _{pp}
Zero level	Referring to GND	+ 2.5 V
Sense level	Input	≥ 400 mV _{pp}
Max. voltage at bus terminals	Referring to GND, including common mode voltage	- 7 V ... + 12 V

Auxiliary Ports		
	Convention EIA / TIA-485	
Data channels	Digital control data	4
Data rate		Up to 10 Mbps
Impedance	Termination	330 Ω
	Source	≤ 10 Ω
Drive level	Output	≥ 2 V _{pp}
Zero level	Referring to GND	+ 2.5 V
Sense level	Input	≥ 400 mV _{pp}
Max. voltage at bus terminals	Referring to GND, including common mode voltage	- 7 V ... + 12 V
	Differential voltage	≤ 6 V _{pp}

RS232 Port		
	Convention EIA / TIA-232	
Data channels	Digital control data	R x D, T x D
Data rate		57 600 Baud

USB Port		
	Remote control input	No transmission purposes

Video		
	Hardware standard 75 Ω / BNC	
Channels		1 x input, 1 x output
Format		Composite Video
Maximum voltages	Output	1.286 V _{pp} ... 1.412 V _{pp} (max)
	Input (Headroom 0.81 dB)	1.412 V _{pp} ≙ 198 IRE
	Reference	1.286 V _{pp} ≙ 180 IRE
Impedance	Input, output	75 Ω
Bandwidth		6 MHz

Word clock		
	Hardware standard 75 Ω / BNC	
Data rate	Depending on used sample rate	Up to 192 kHz
Impedance	Output	75 Ω
	Input	1k / 75 Ω software switch
Drive level	Output	≥ 2 V _{pp}
Zero level	Referring to GND	+ 2.5 V
Sense level	Input	≥ 400 mV _{pp} AC-coupled

Link		
	Input, Output, Dual – Full bandwidth	
Connection		Duplex SC
Protocol		Optocore
Transmission		Full duplex
Data rate		2 x 1 Gbps
Optical wave guide cable lengths	Multimode fiber 50 μm	≤ 700 m
	Multimode fiber 62.5 μm	≤ 350 m (not recommended)
	Monomode fiber 9 μm	≤ 70 km (on request)

Power supply		
	2 independent power supplies with function check and automatic switch-over	
Type	Switch-mode, universal input	
Mains voltage	100 ... 240 V, 400 V _{AC} tolerant	
Frequency	50 ... 60 Hz	
Power consumption	16 VA-idle, 22 VA-peak	
Fuse	D1.0 A, slow behavior, glass 5 mm x 20 mm, acc. to UL 48-14	
Inrush current limit	≤ 7 A	
Protection circuit	400 V _{AC} tolerance, over-voltage, over-current and over-temperature monitor	
Security classification	Class 1: basic insulation, connected to the protective grounding conductor	
Security regulations	Harmonized European standard EN60065	
Mains connector	Including EMI-filter, a fuse and spare-fuse, acc. to IEC-950	
Cooling	Via surface and ventilation-slits on both sides	

Dimensions and Weight

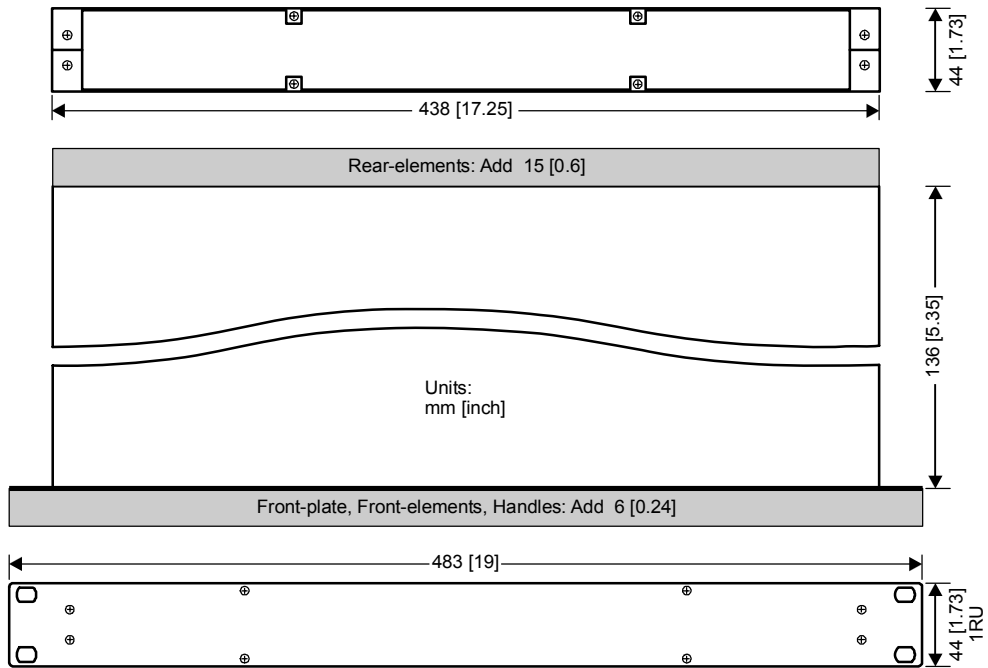

Weight

2.3 kg \approx 5.1 lbs

Modifications that serve the purpose of technical improvement of the device may be carried out without prior notification.

Warranty

Summary of Warranty

Optocore PTP32E is warranted against defects in material and workmanship for 24 months.

This warranty covers the original purchaser only and is not transferable. Valid evidence for warranty is the official Optocore invoice issued by the distributor / dealer.

Optocore will, at its discretion, repair or replace a defective product, providing that the defect has appeared under normal operating conditions.

This warranty does not cover damage from acts of God, accident, abuse, neglect, contamination, unauthorized modification or misuse, operation outside of the environmental specifications for the product, improper site preparation or maintenance, or abnormal conditions of handling. This would include over-voltage failures, and conditions outside of the products specified ratings, problems with buyer-supplied software or interfacing, or normal wear and tear of mechanical components. Optocore or its distributor / dealer will acknowledge the evaluation of warranty after inspection.

Devices on which the Serial Number has been removed or defaced are not eligible for warranty service.

Failure to properly package and protection of the product during shipping may void this warranty.

How to Obtain Warranty Service

To return a defective product, please contact your distributor / dealer. Our web site: <http://www.optocore.com/> provides a complete list of Optocore distributors / dealers.

Always ensure the careful handling of the device. If possible transport or shipping should always occur in special, shock-absorbing transport cases. If these are not available we recommend well-upholstered packaging such as the coated carton in which the device was delivered.

We strongly advise not to use simple flight-cases without rack-in-rack mounting.

Declaration of Liability

Optocore accepts no liability for damage caused to other devices through operation of the PTP32E device.

Optocore is not liable for any damage caused by shipping accidents, misuse, abuse, operation with incorrect AC voltage, operation with faulty peripheral equipment, or improper or careless installation of the device.

Optocore accepts no claims for compensation whatsoever (e.g. cancellation of events).

Shipping Contents

The standard shipment of a PTP32E device contains the following:

- 1 PTP32E device
- 1 SC-SC patch cable (2m)
- 2 D1.0A (1.0A, slow behavior) replacement fuses per device
inserted next to the operational fuses in the power supply units.
- 1 operating manual

Any additionally purchased equipment such as optical wave-guide cables in required lengths, D-Sub cables and adapters, RS232 cables, and international electric cables have been supplied on your request and your purchase order and cannot be listed in the above.

Company Information

Mailing Address:

OPTOCORE GmbH
Lisbergstr. 7
D-81249 Munich
Germany

Telephone:

+49 – (0)89 – 8999640

Facsimile:

+49 – (0)89 – 89996455

Internet:

www.optocore.com

Email:

Inquiry@optocore.com